

TL

ASPIRATORE VENTILATORE CENTRIFUGO
CENTRIFUGAL FAN

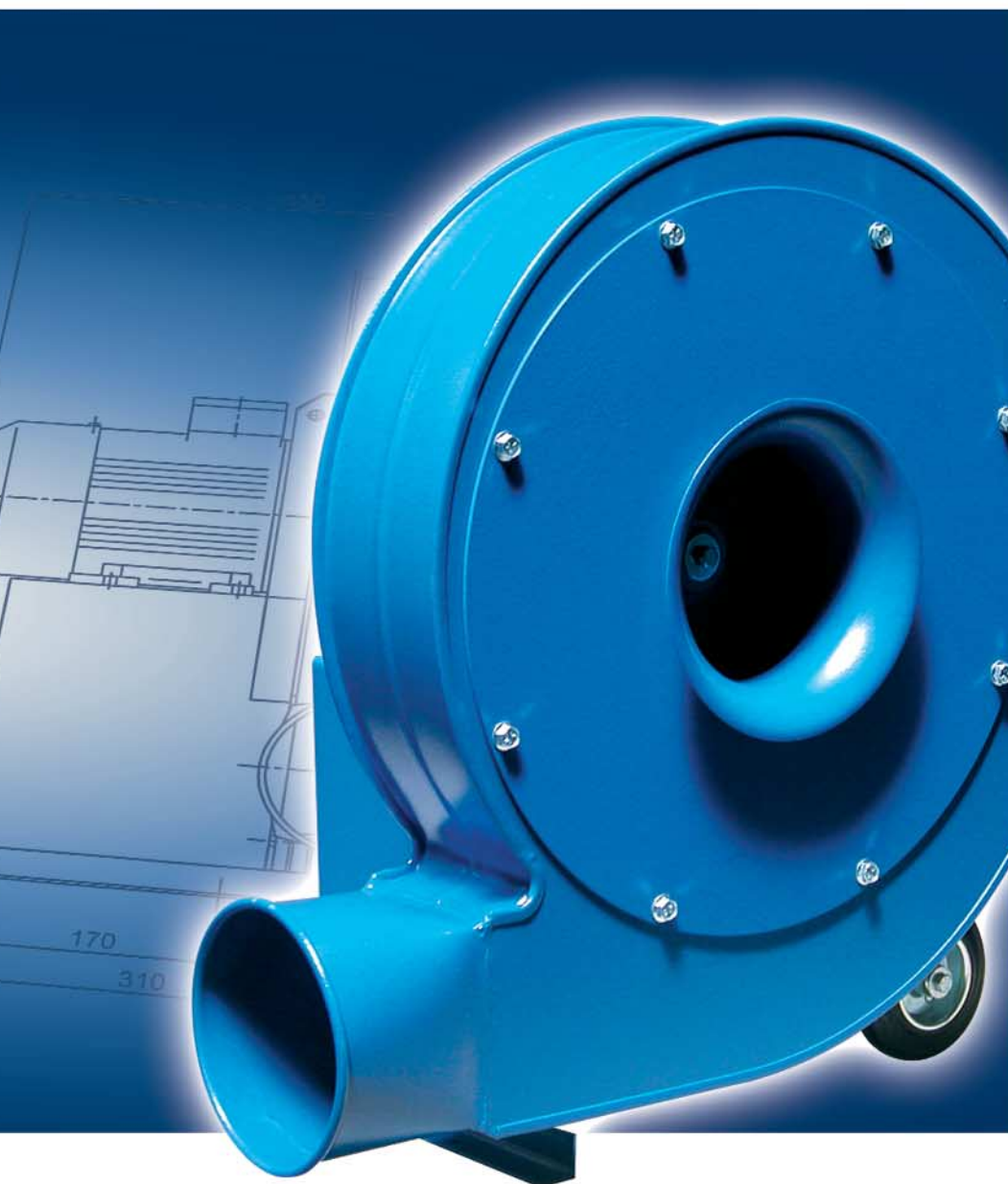

GIRANTE A PALE CURVE ROVESCE
BACKWARD CURVED BLADES IMPELLER



ALTA PRESSIONE
HIGH PRESSURE

Portata/Flow rate:
100 ÷ 2700 m³/h

Pressione/Pressure:
590 mm H₂O





TL

ASPIRATORE VENTILATORE CENTRIFUGO CENTRIFUGAL FAN

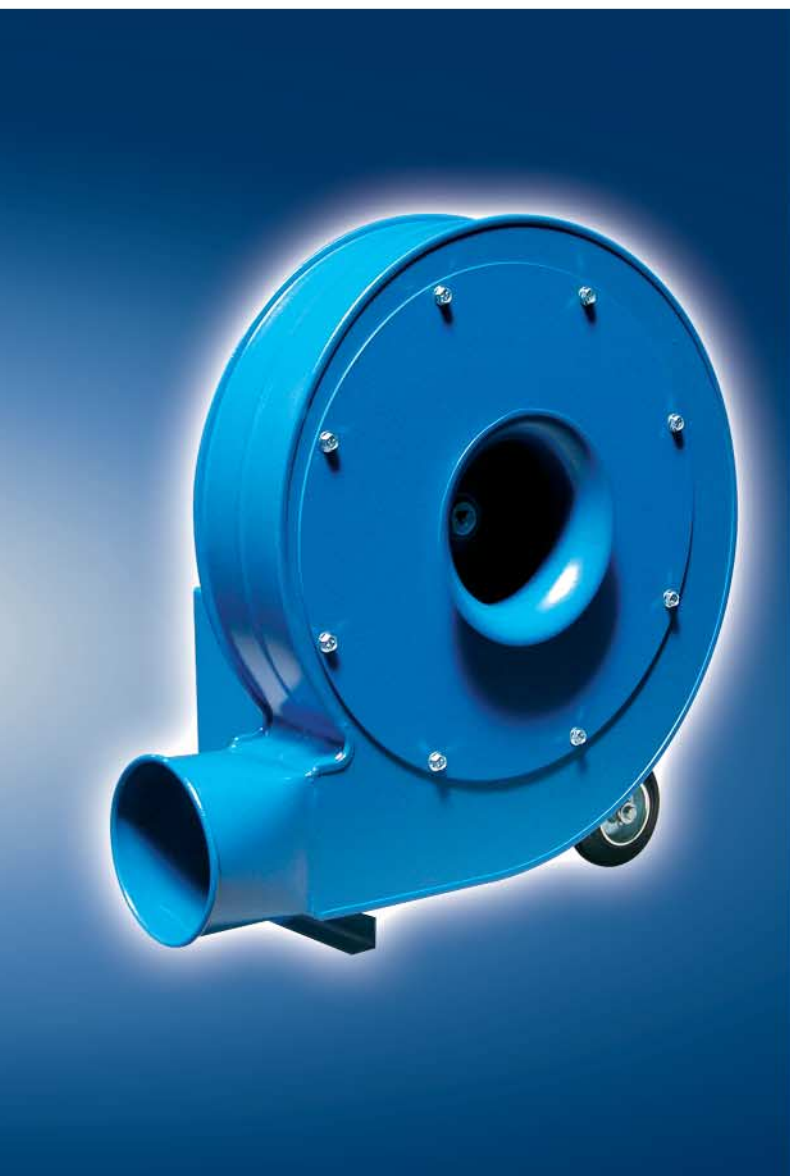

Ventilatore ad alto rendimento: Mod. TL.

Campo di lavoro: portate piccole e medie, prevalenze alte.

Tipo di pale: rovesce.

Applicazioni: adatto per trasporto pneumatico di granuli in plastica, materiali solidi in miscela con aria con ventilatore non attraversato.

Temperatura del fluido: fino a 60° C in esecuzione standard; esecuzioni speciali per temperature superiori.

Caratteristiche costruttive: ventilatore di costruzione particolarmente robusta eseguito in lamiera verniciata, ventola in acciaio equilibrata staticamente e dinamicamente.

Caratteristiche di funzionamento: condizionell'aria in aspirazione $T = 15^{\circ} \text{C}$, $p = 1 \text{ atm}$.

High efficiency fan: Mod. TL.

Field of application: medium and low capacities, high pressures.

Type of blades: backward.

Applications: suitable for pneumatic conveyance of plastic chips, solid material mixed to air, if blower is not crossed.

Air temperatue: up to 60° C standard, special features for higher temperatures.

Construction specifications: rigid construction in sheet metal.

Statically and dynamically balanced impellers.

Working principles: condition of the ducted air $T = 15^{\circ} \text{C}$, $p = 1 \text{ atm}$.



MERO

DIMENSIONI D'INGOMBROE CARATTERISTICHE TECNICHE OVERALL DIMENSIONS AND TECHNICAL SPECIFICATIONS

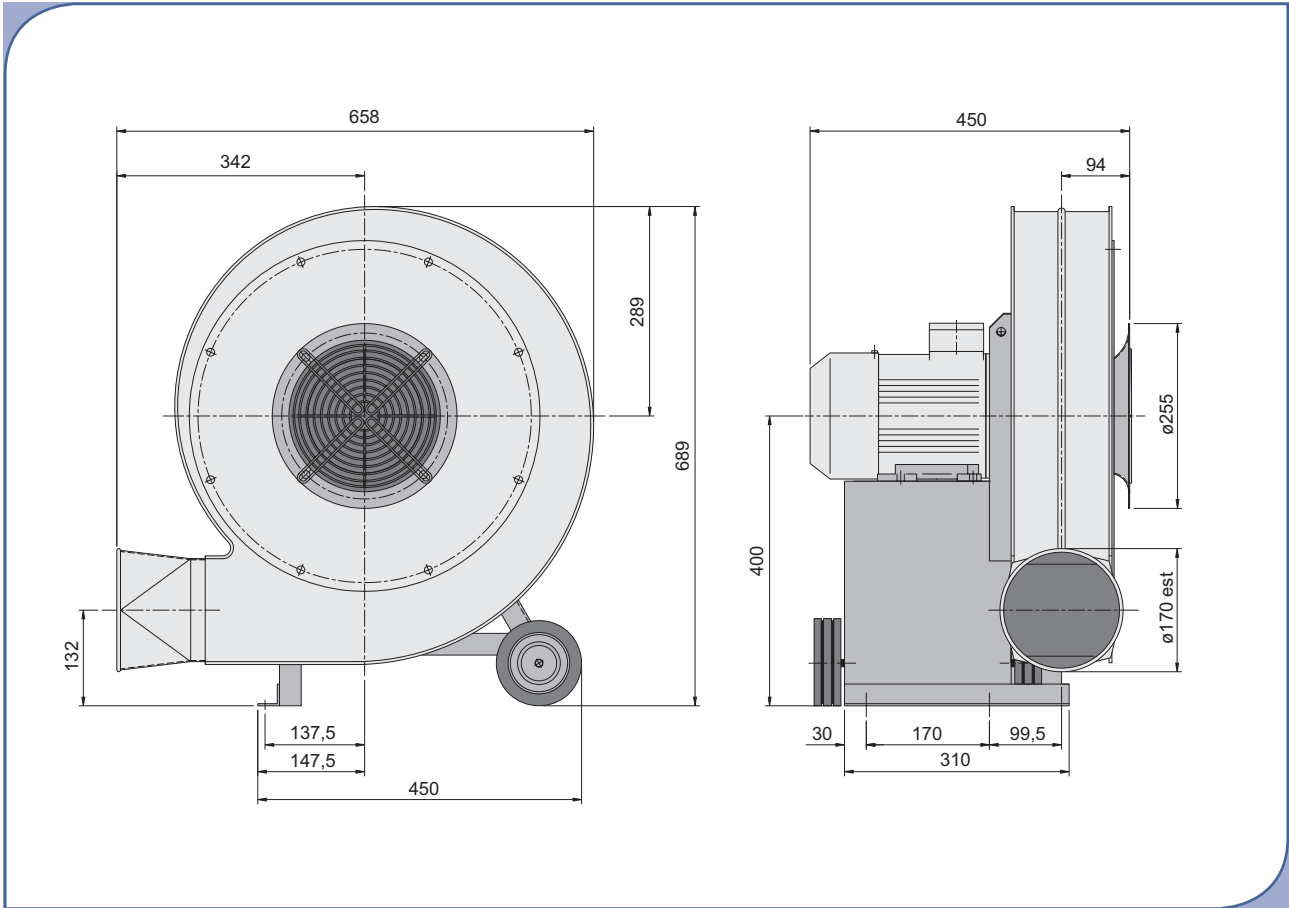

TL 20

Potenza installata 1,5 kW
Motor power 1,5 kW

Voltaggio 230/400 V
Motor voltage 230/400 V

Peso ventilatore in kg 35
Weight of ventilator in kg 35

Massima velocità di rotazione 2850
Maximum rotation speed 2850

Girante: ø430 a pale rovesce
Impeller: ø430 backward blades

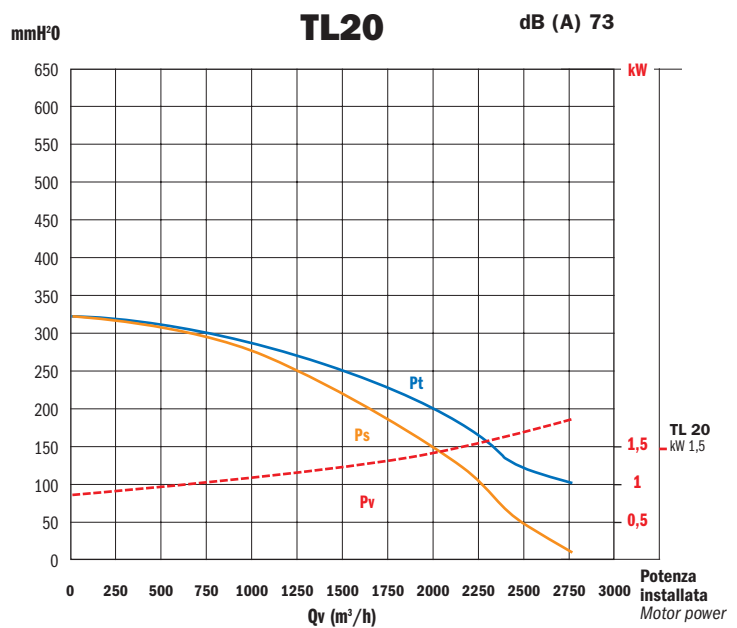

Valori riferiti a: / Datas referring to: T=15°C; P=1 atm

— Pt= Pressione totale - Total pressure — Ps= Pressione statica - Statical pressure - - - Pv= Potenza assorbita - Absorbed power

DIMENSIONI D'INGOMBROE CARATTERISTICHE TECNICHE

OVERALL DIMENSIONS AND TECHNICAL SPECIFICATIONS

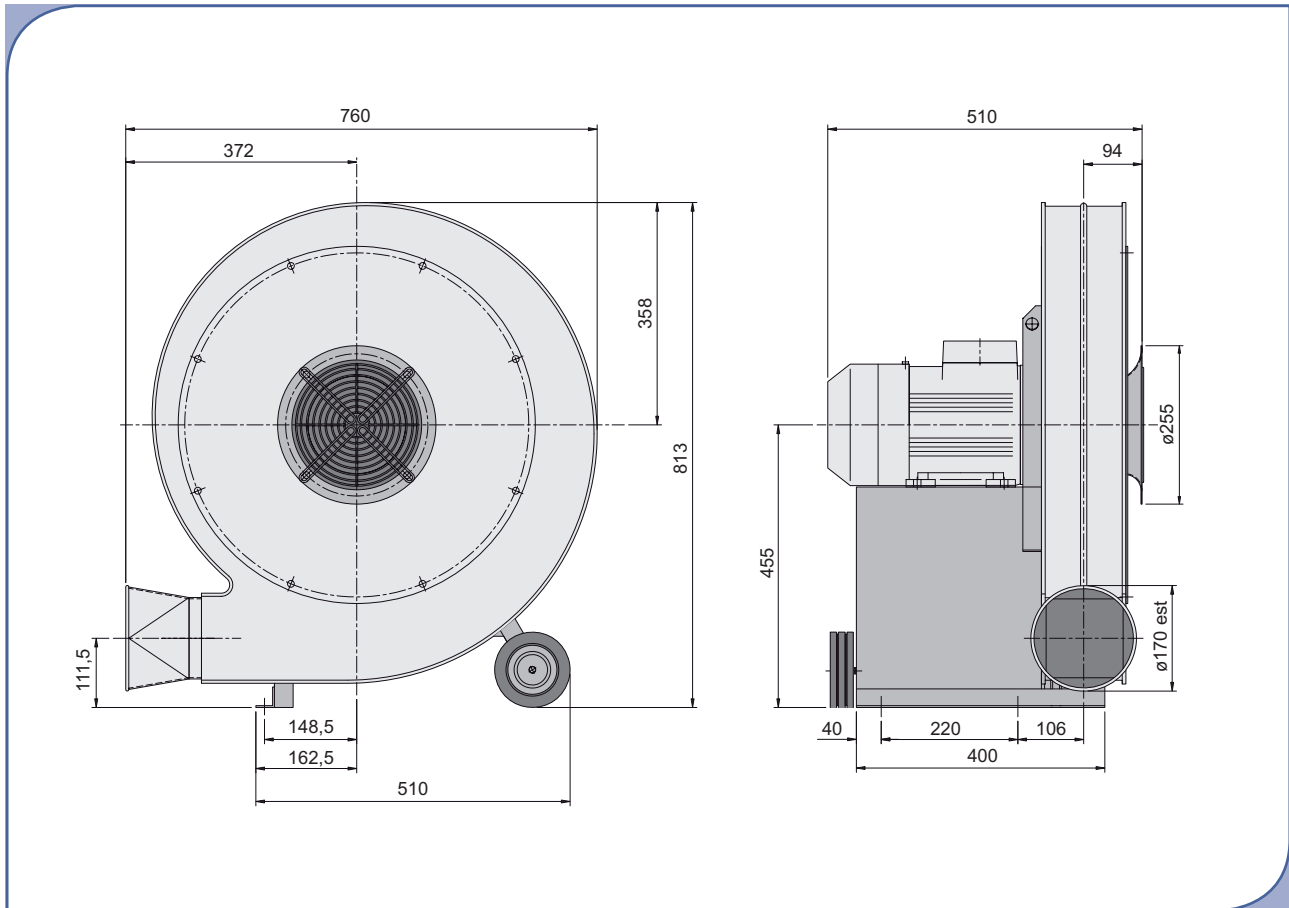

TL 40

Potenza installata 3 kW
Motor power 3 kW

Voltaggio 230/400 V
Motor voltage 230/400 V

Peso ventilatore in kg 67
Weight of ventilator in kg 67

Massima velocità di rotazione 2850
Maximum rotation speed 2850

Girante: $\phi 520$ a pale rovesce
Impeller: $\phi 520$ backward blades

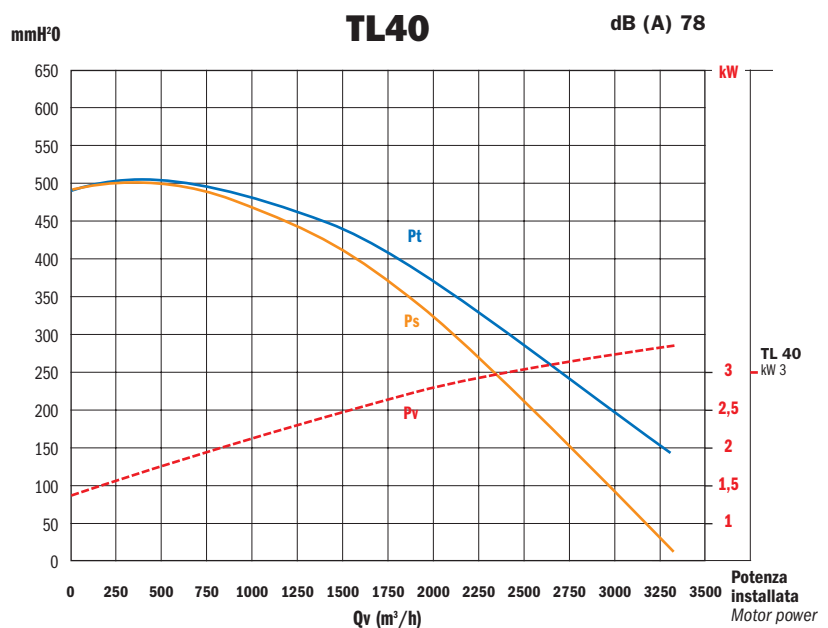

Valori riferiti a: / Datas referring to: T=15°C; P=1 atm

— Pt= Pressione totale - Total pressure — Ps= Pressione statica - Statical pressure - - - Pv= Potenza assorbita - Absorbed power

MERO

DIMENSIONI D'INGOMBROE CARATTERISTICHE TECNICHE OVERALL DIMENSIONS AND TECHNICAL SPECIFICATIONS

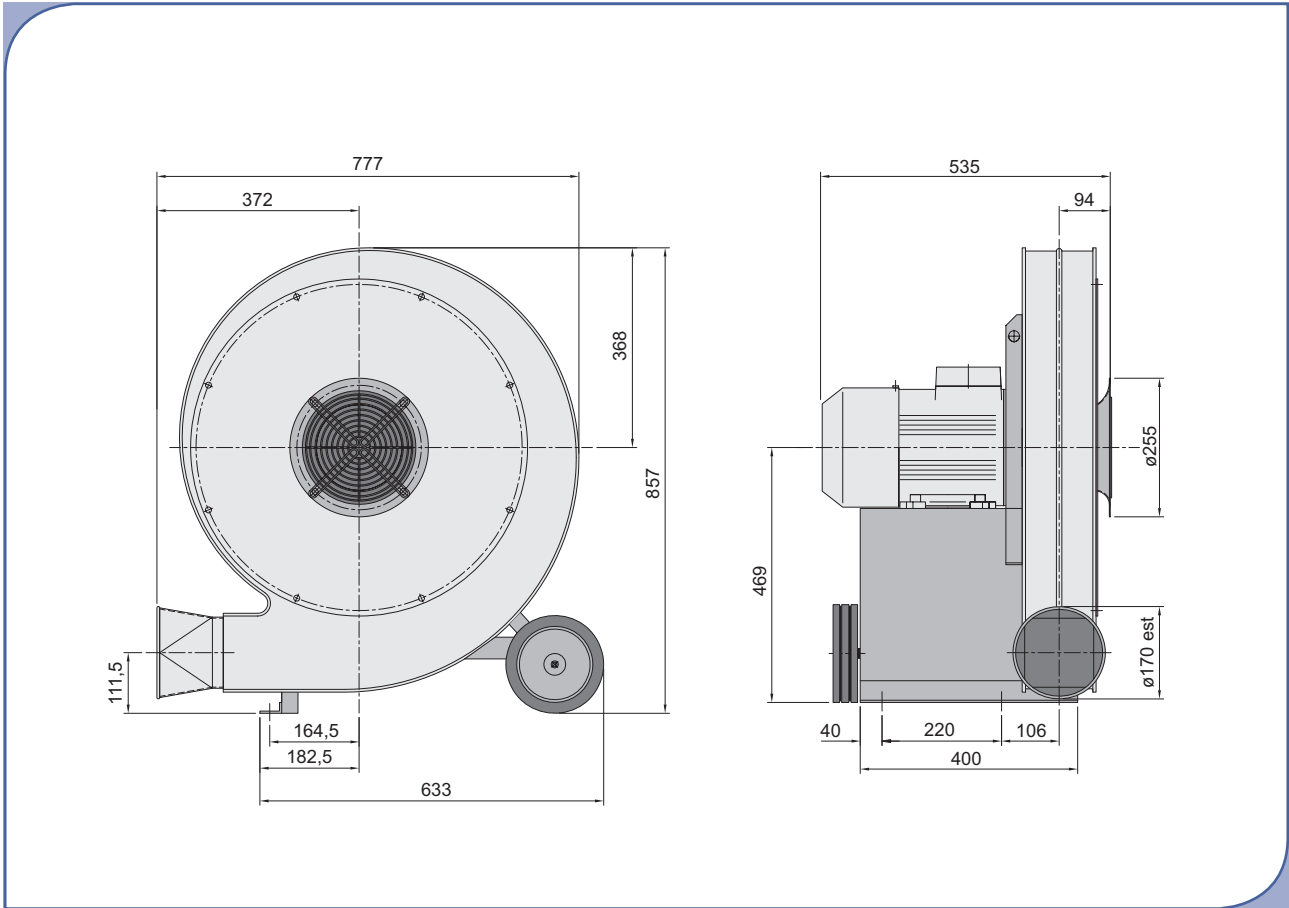

TL 55

Potenza installata 4 kW
Motor power 4 kW

Voltaggio 230/400 V
Motor voltage 230/400 V

Peso ventilatore in kg 76
Weight of ventilator in kg 76

Massima velocità di rotazione 2850
Maximum rotation speed 2850

Girante: ø570 a pale rovesce
Impeller: ø570 backward blades

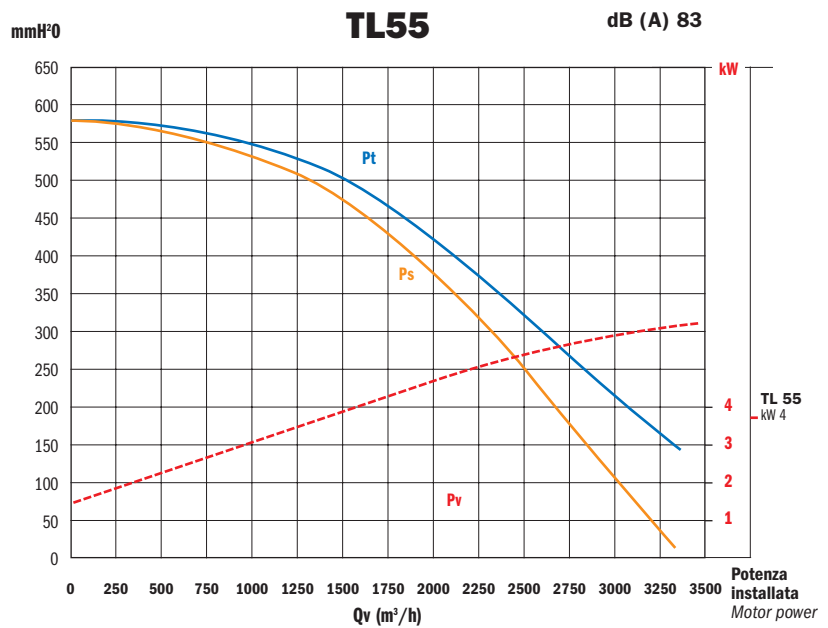

Valori riferiti a: / Datas referring to: T=15°C; P=1 atm

— Pt= Pressione totale - Total pressure — Ps= Pressione statica - Statical pressure - - - Pv= Potenza assorbita - Absorbed power

DIMENSIONI D'INGOMBROE CARATTERISTICHE TECNICHE

OVERALL DIMENSIONS AND TECHNICAL SPECIFICATIONS

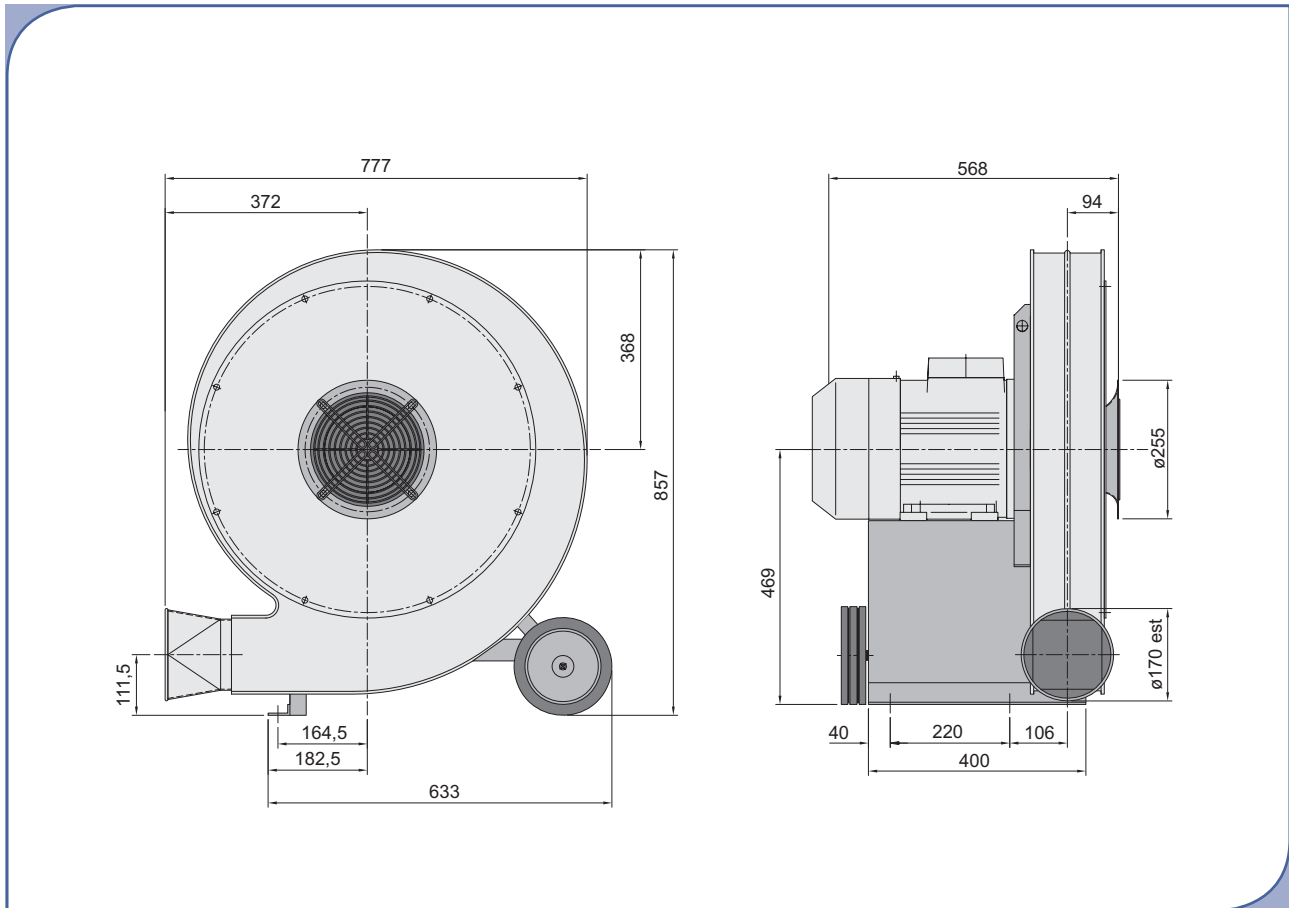

TL 75

Potenza installata 5,5 kW
Motor power 5,5 kW

Voltaggio 400/690 V
Motor voltage 400/690 V

Peso ventilatore in kg 96
Weight of ventilator in kgf 96

Massima velocità di rotazione 2850
Maximum rotation speed 2850

Girante: $\phi 570$ a pale rovesce
Impeller: $\phi 570$ backward blades

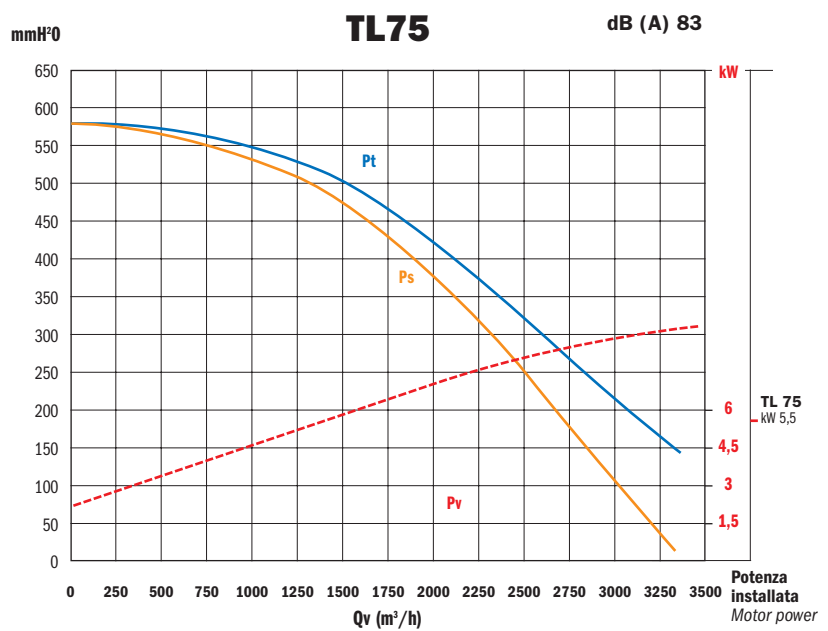

Valori riferiti a: / Datas referring to: T=15°C; P=1 atm

— Pt= Pressione totale - Total pressure — Ps= Pressione statica - Statical pressure - - - Pv= Potenza assorbita - Absorbed power